

LC-XB12100P*1

For standby power supplies.
Expected trickle design life: 10 – 12 years at 20°C according to Eurobat.

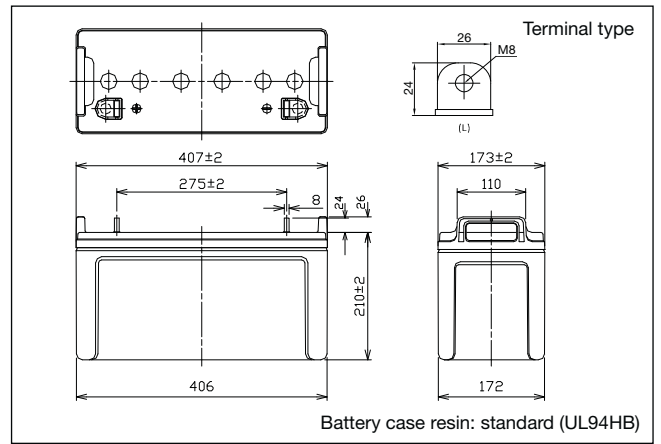

Dimensions (mm)



Specifications

Nominal voltage	12V	
Nominal capacity (20 hour rate)	100Ah	
Dimensions	Length	407mm
	Width	173mm
	Height	210mm
	Total Height	236mm
Approx. mass	36.5kg	
Terminal	M8 Bolt and Nut type	

Duration of discharge vs Discharge current

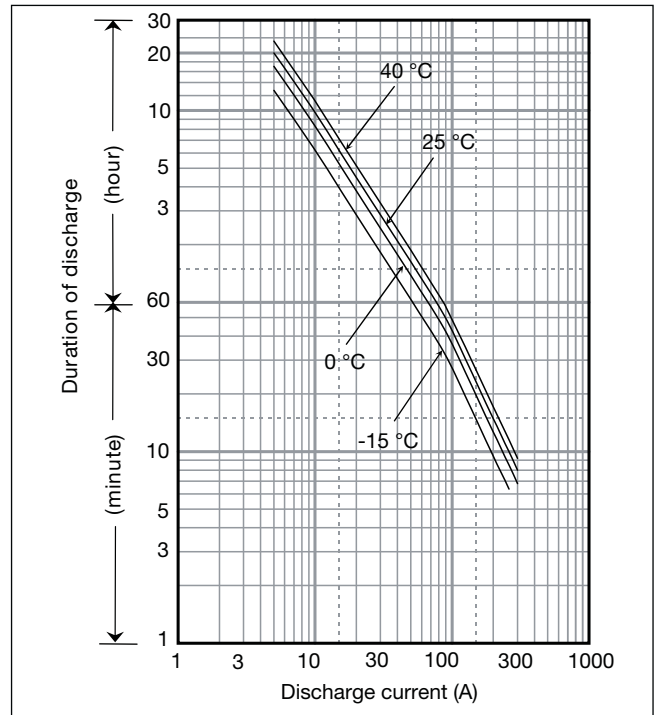

Characteristics

Capacity (25°C)	20 hour rate 10 hour rate 5 hour rate 1 hour rate	100Ah 98Ah 90Ah 70Ah
Internal resistance	Fully charged battery (25°C)	4.5mΩ
Temperature dependency of capacity (20 hour rate)	40°C	102%
	25°C	100%
	0°C	85%
	-15°C	65%
Self discharge (25°C)	After 3 months	91%
	After 6 months	82%
	After 12 months	64%

Watt Table

(Wattage/Battery)

Cut-off V	10min	15min	20min	30min	45min	1h	1.5h	2h	3h	4h	5h	6h	10h	20h	24h
9.6V	2306	1834	1592	1206	892	733	582	430	281	226	170	154	88.3	47.0	38.5
9.9V	2254	1790	1554	1177	869	714	567	419	276	221	165	149	85.3	47.0	38.5
10.2V	2204	1726	1498	1139	877	694	551	413	272	216	160	145	84.3	46.5	38.0
10.5V	2134	1705	1487	1130	852	675	536	405	267	213	160	145	83.3	46.5	38.0
10.8V	1947	1624	1479	1094	840	666	528	395	262	208	155	150	82.3	45.5	37.2

Ampere Table

(Ampere/Battery)

Cut-off V	10min	15min	20min	30min	45min	1h	1.5h	2h	3h	4h	5h	6h	10h	20h	24h
9.6V	265	201	174	130	92.0	76.3	52.0	41.3	27.7	21.4	18.6	15.6	9.9	5.0	4.2
9.9V	262	200	173	129	89.5	76.0	51.0	41.0	27.2	21.2	18.3	15.6	9.9	5.0	4.2
10.2V	261	199	171	127	89.0	75.5	50.6	40.5	27.0	21.0	18.0	15.5	9.8	5.0	4.2
10.5V	238	188	163	125	88.0	75.0	50.0	40.0	27.0	21.0	18.0	15.5	9.8	5.0	4.2
10.8V	226	182	159	123	76.0	65.0	45.0	38.0	25.8	20.5	17.8	15.0	9.7	4.9	4.2

*1 This battery is also available with a flame retardant battery case resin (UL94 V-0).

Charging Method

Trickle use Control voltage: 13.6 - 13.8V; Initial current 15A or smaller

Cut off voltage

Discharge current	5A - 20A	20A - 50A	50A - 100A	100A - 200A	200A - 300A
Cut off voltage (V)	10.5	10.2	9.9	9.3	8.7

Influence of Temperature on Trickle life

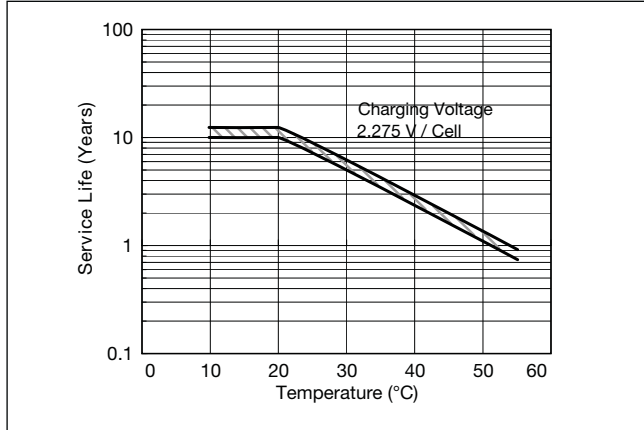

Residual capacity vs storage period

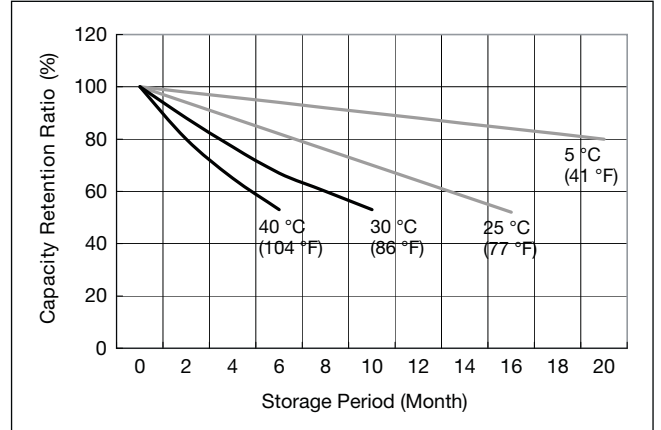

Constant-voltage and constant-current charge characteristics for Trickle use

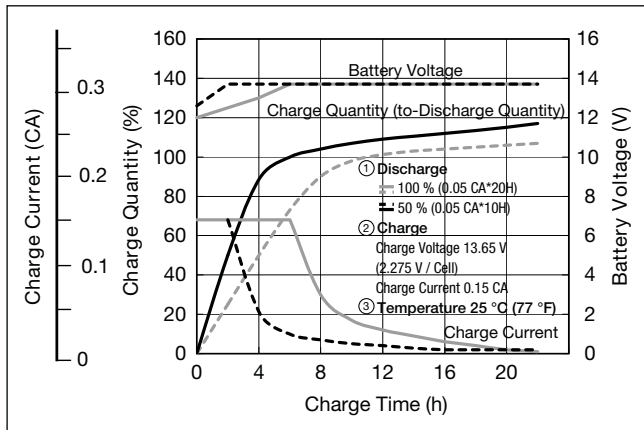

Discharge capacity by temperature and by discharge current

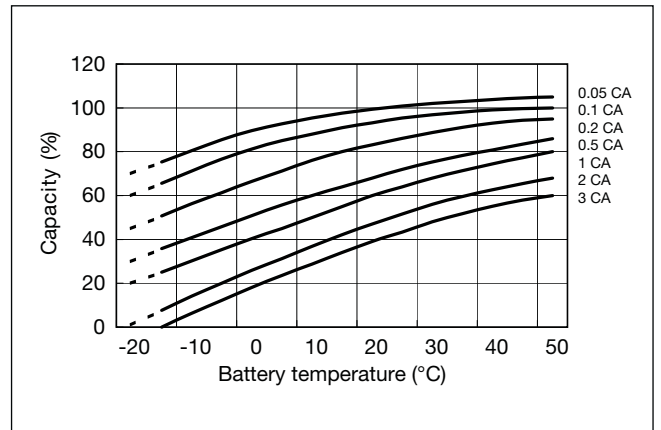

Discharge characteristics

